









# Installation & Setup

## Installation & Setup

⚠ WARNING!	
    	<p><b>The appliance owner is responsible</b> for performing a Personal Protective Equipment (PPE) hazard Assessment and to ensure adequate protection during maintenance and cleaning procedures.</p> <p><b>Use appropriate tools</b>, safety equipment, and PPE during installation and servicing.</p>
	<p><b>Sharp edges!</b> Take care when moving, installing, cleaning, servicing and maintaining the appliance to avoid cuts. Be sure to take care when reaching under the appliance or handling metal components. Keep fingers out of pinch point areas, such as the space between appliance doors and surrounding appliances. Take care closing doors with children nearby.</p>
	<p><b>Risk of electrical shock or burn!</b> Powering off an electronic control or setting temperature controls to the 0 (off) position does not remove power from all components. Unplug the appliance or turn off the power supply before installation or servicing.</p>
	<p><b>Tip over hazard!</b> Appliance may pose a tipping hazard when uncrating, installing or moving the appliance. Take appropriate safety precautions. Use of tip over restraints may only reduce (not eliminate) the tipping hazard. Never allow children to climb or hand on drawers, doors or shelves.</p>
	<p><b>Crush or cut hazard!</b> Keep clear when uncrating, installing, moving, or servicing the appliance.</p>

### Uncrating

ⓘ USER ACTION!	
	<ul style="list-style-type: none"> <li>• If the appliance is damaged, note all damage on the delivery receipt, immediately file a claim with the delivery freight carrier, and contact TRUE. <b>DO NOT install the unit or put it in service.</b></li> <li>• If the unit laid on its back or side, be sure to leave the unit upright twice the time it has been laying down (up to four (4) hours) before plugging the unit into a power source. If this time exceeds four (4) hours, let the unit sit upright for 24 hours before powering the unit.</li> </ul>

ⓘ NOTICE!	
	<p>Keys for appliances with door locks are located in the warranty packet.</p>

### Required Tools

Required tools include (but may not be limited to) the following:

- Adjustable wrench
- Phillips screwdriver
- Level

## Installation & Setup (cont.)

### Procedure

1. Remove the outer packaging (cardboard, bubble wrap, foam corner, clear plastic, ect.). See fig. 1.

**NOTICE >** **DO NOT** remove the glass swing door shipping brackets (see fig. 2) until the appliance is installed in its final location. **Do not discard;** use the bracket when next moving the appliance.

2. With an adjustable wrench, remove all shipping bolts securing the wood skid to the bottom of the cabinet. See fig. 3.

**NOTICE >** Move the appliance as close as possible to the final location before removing the wooden skid. Your appliance may require removing the front and/or rear grill/cover to access the shipping bolts.

3. If leveling legs or castors **will not be used**, remove the appliance from the wood skid and set the skid aside.

If leveling legs or castors **will be used**, rotate the appliance on the skid (see fig. 4) and see the installation instructions on page 13.

**NOTICE >** **DO NOT** lift the cabinet by the counter tops, doors, drawers, or grills.

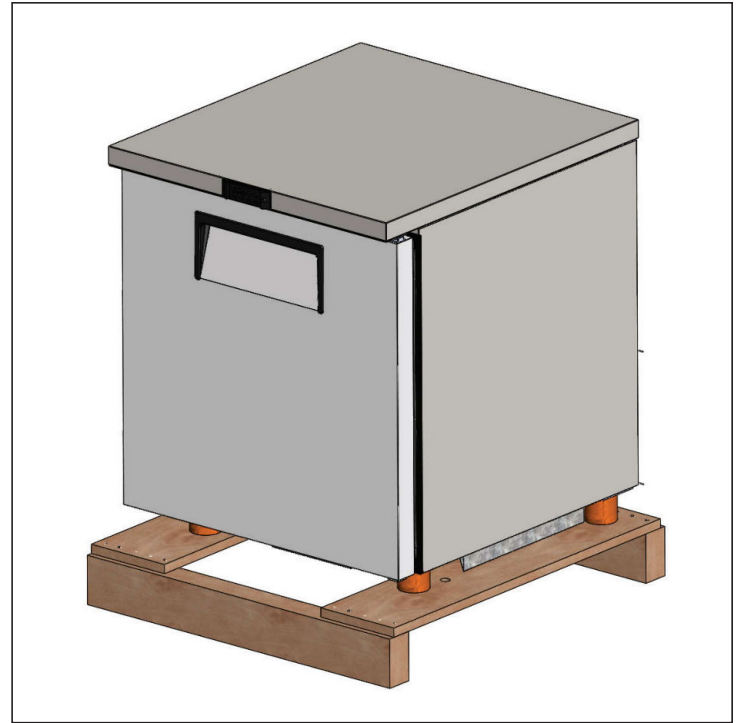

**Fig. 1.** Remove exterior packaging.



**Fig. 2.** Do not remove shipping brackets until unit is in final location.



Installation & Setup (cont.)



Fig. 3. Remove all shipping bolts.

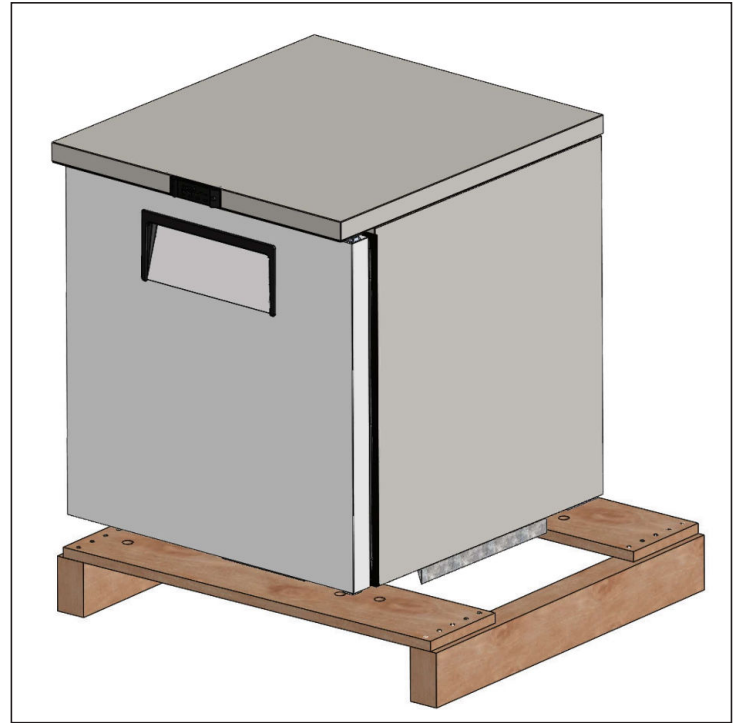

Fig. 4. Rotate cabinet on skid to install leveling legs or castors.

Appliance Location

- Ensure that the drain hose or hoses are positioned in the pan.
- Free the plug and cord from inside the lower rear of the cooler (**DO NOT** plug in).
- Place the appliance close enough to the electrical supply so that extension cords are never used.

Leveling Screw, Leg, or Castor Installation

⚠ **WARNING!**

**Tipping hazard!** Incorrect installation of leveling legs or castors can cause a tipping hazard.

**ALWAYS** be sure leveling legs or castors (and shims) are snug against the rail assembly or mounting plate.

**ALWAYS** verify center castors or leveling legs fully contact the floor after leveling the appliance. See fig. below.

Leveling legs are provided to assist with leveling the appliance. Adjustable legs provide 6" (152 mm) of clearance under the appliance. Castors provide appliance mobility.

## Installation & Setup (cont.)

### Required Tools

Required tools include (but may not be limited to) the following:

- Adjustable Wrench

### Procedure – Leveling Screws

#### ⓘ USER ACTION!



TUC-24 Models: Lower the front leveling legs so the unit remains stationary when opening the door.

If leveling screws are not factory installed, then, with access to the appliance bottom, install the leveling screws into the threaded holes in the frame rail or appliance bottom. See figs. 1–3.



**Fig. 1.** Leveling screw.

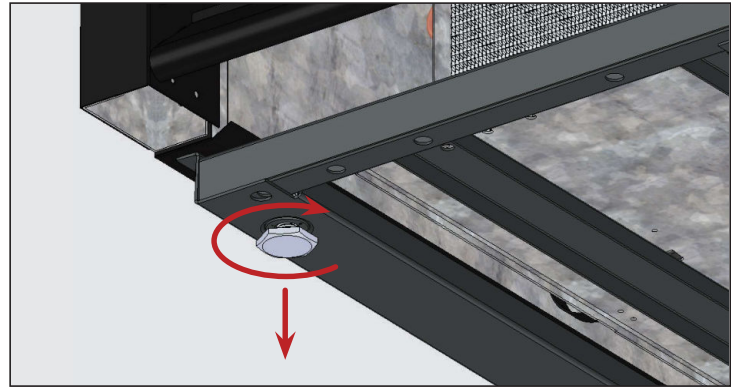

**Fig. 2.** Turn the leveling screws clockwise to lower the appliance.

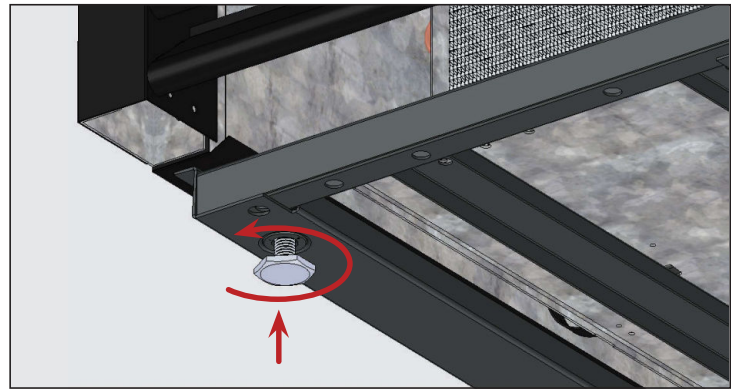

**Fig. 3.** Turn the leveling screws counterclockwise to raise the appliance.

# Installation & Setup (cont.)

## Procedure – 6" (152 mm) Leveling Legs

1. Access the appliance bottom.
2. If present, remove the leveling screws.
3. Thread the leveling legs into the frame rail or appliance bottom. See figs. 4 and 5.
4. Verify that the appliance is level. See "Level Appliance" (pg. 17).
5. If the appliance is not level, gently lift and support the low end of the appliance. Then, with an adjustable wrench, screw the leveling leg bottom stems in or out to level and support the appliance. See fig. 4 and 6.

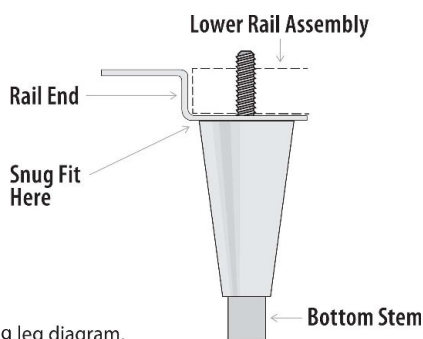

Fig. 4. Leveling leg diagram.

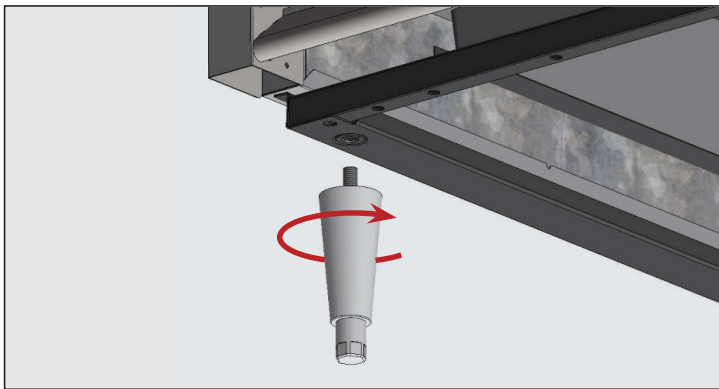

Fig. 5. Screw the leveling legs into the threaded holes.

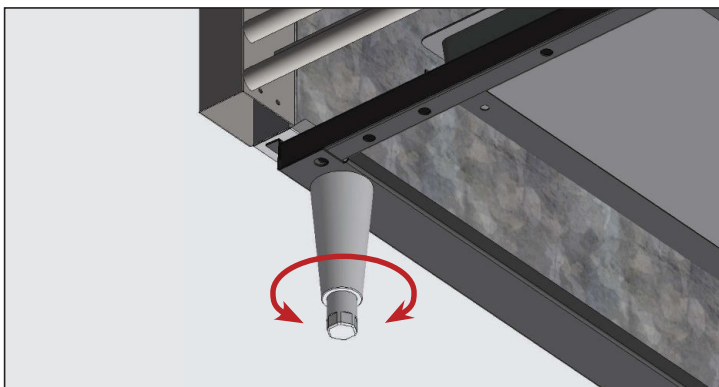

Fig. 6. Turn the bottom stem to level the appliance.

## Procedure — Castors

**NOTICE >** Install castors with brakes in the front.

1. Access the appliance bottom.
2. If present, remove the leveling screws.
3. Thread the castors into the frame rail or appliance bottom. See figs. 7 and 8.
4. Verify the appliance is level. See "Level Appliance" (pg. 17).
5. On the low end of the appliance, loosen the castor bolt enough to slide provided castor shims between the castor bearing and the bottom rail of the appliance. See fig. 9.
6. Install the desired number of shims. See fig. 9.
  - If more than one shim is used, be sure shim slots are offset. See fig. 10.
  - **DO NOT** use more than four (4) shims on a castor.
  - Be sure each shim touches the castor stem.
7. Tighten and secure the shims and castors.
8. Verify the appliance is level.
9. If the appliance is not level, repeat the steps 3 – 6 until the appliance is level and supported.

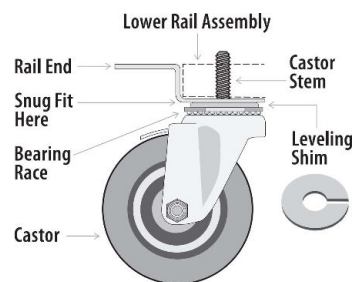

Fig. 7. Castor diagram.

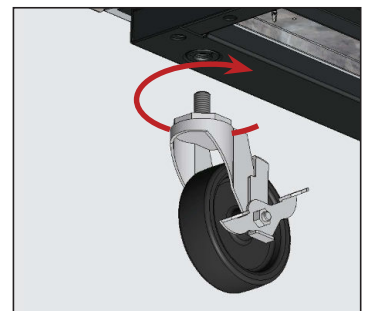

Fig. 8. Screw the castors into the threaded holes.

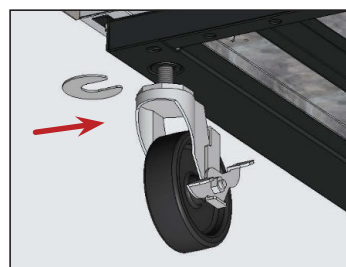

Fig. 9. Insert the castor shim(s). be sure to tighten the castor stem.

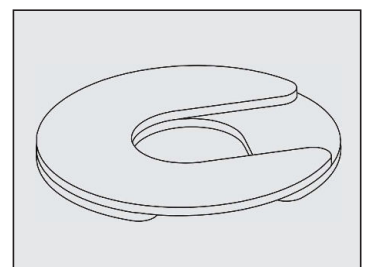
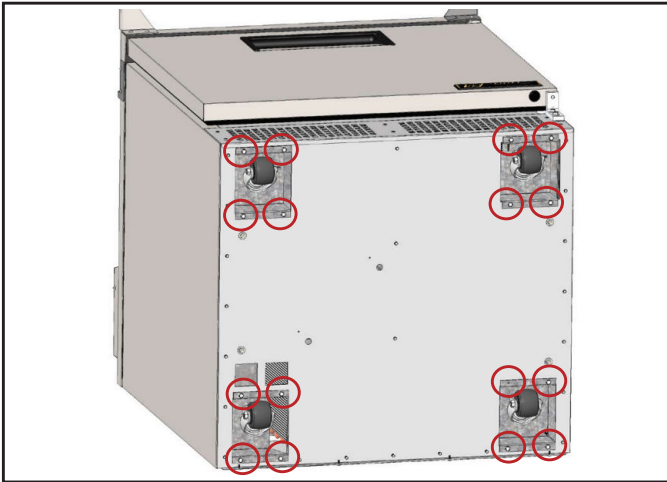

Fig. 10. Install multiple shims with offset slots.

## Installation & Setup (cont.)

### Procedure – Castors (TFP Models Only)

1. Position packing material behind the appliance and carefully lay the appliance on its back.
2. Remove the castor box. See fig. 11.  
**NOTICE >** Each appliance has one castor box that completely encloses the castor. With a 1/4" hex-head driver, disassemble the castor box. See fig. 12.
3. Install the desired number of shims. See previous page for instructions.
4. Tighten and secure the shims and castor with optional castor wrench.
5. Install the castor box.
6. Carefully raise the appliance to an upright position and verify the level. If the appliance is not level, repeat the process until the appliance is level and supported.



**Fig. 11.** Locate castor box. Back out the four screws anchoring the box.

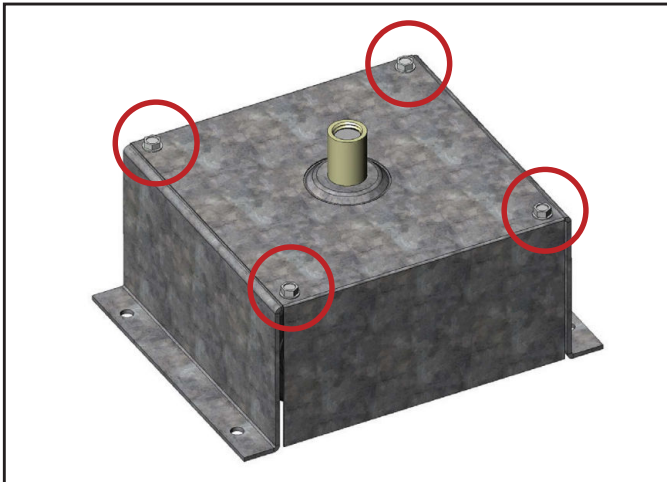

**Fig. 12.** One castor box on each cabinet is fully enclosed.

# Installation & Setup (cont.)

## Level Appliance

<b>⚠ WARNING!</b>	
	<p><b>Tipping hazard! ALWAYS</b> verify center leveling screws fully contact the floor after leveling the appliance.</p>

Proper leveling of your TRUE appliance is critical to operating success (for non-mobile appliances). Leveling impacts effective condensate removal and door operation.

See "Leveling Screw, Leg or Castor Installation" (pg. 13) for level adjustment and shimming information.

### Procedure

Position the appliance in its final installation location. Then, level the appliance front-to-back and side-to-side. See fig. 1.

1. Position the level on the inside floor of the unit near the doors (level parallel to appliance front). Level the appliance.
2. Position the level at the inside rear of cabinet (level parallel to appliance back). Level the appliance.
3. Position the level on the left and right inside floor (level parallel to appliance sides). Level the appliance.

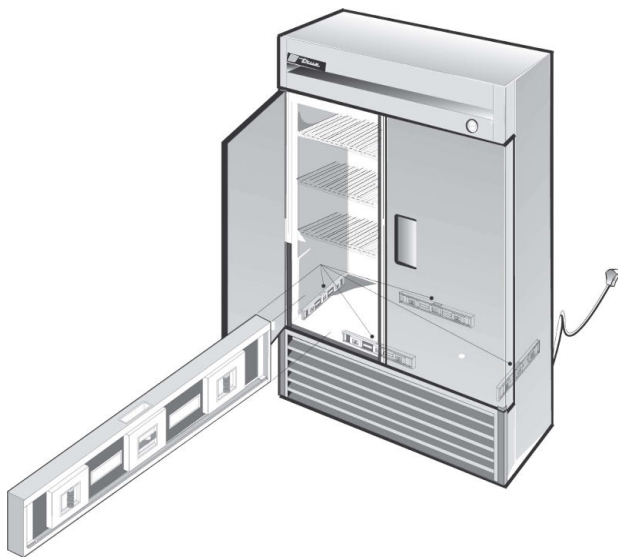

**Fig. 1.** Measure the level along the perimeter of the interior floor.

## Sealing the Appliance to the Floor

<b>ⓘ USER ACTION!</b>	
	<p>Asphalt floors are susceptible to chemicals. TRUE recommends installing a layer of tape between the asphalt and the sealant to protect the floor.</p>

The following procedure describes sealing a non-mobile appliance to the floor for NSF standards. This may not be required for your application.

### Procedure

1. Position the appliance in its final installation location. Be sure to leave adequate clearance between the back and sides per "Clearances" (pg. 9) to ensure proper ventilation.
2. Level the appliance front-to-back and side-to-side. See "Level Appliance" (pg. 17).
3. Draw an outline of the appliance base on the floor.
4. Raise and block the front side of the appliance.
5. Apply a bead of NSF-approved sealant (see list below) to the floor, 1/2" (13 mm) inside the front part of the outline drawn in step 4. The bead of sealant must be heavy enough to seal the entire appliance surface when the appliance is lowered on top of the sealant.
6. Raise and block the rear of the appliance.
7. Apply sealant to the floor on the other three sides, as outlined in step 5.
8. Examine the appliance to ensure that it is sealed to the floor around the entire perimeter.

### NSF-Approved Sealants

- 3M #ECU800 Caulk
- 3M #ECU2185 Caulk
- 3M #ECU1055 Bead
- 3M #ECU1202 Bead
- Armstrong Cork – Rubber Caulk
- Products Research Co. #5000 Rubber Caulk
- G.E. Silicone Sealer
- Dow Corning Silicone Sealer

## Installation & Setup (cont.)

### Shelf Installation

#### ⚠ WARNING!



**Overloading, incorrectly installing, or improperly loading shelves** can cause shelf failure and negatively affect appliance operation, resulting in appliance damage, product damage, or personal injury.

**DO NOT use pliers or any crimping tools** when installing shelf clips. Altering shelf clips in any way can lead to shelving instability.

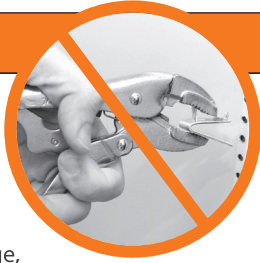

#### Installation Tips

- Install **all** the shelf clips before installing any shelves.
- Start at the bottom shelf and work your way up.
- Always lay the back of each shelf down on the rear clips before the front.

#### Procedure

1. Hook the shelf clips into the shelf standards. See fig. 1.
2. Push up on the bottom of the clip. See fig. 2.
  - NOTICE >** You may need to squeeze or twist the bottom of the shelf clip for proper installation. Position all four shelf clips equal in distance from the floor for flat shelves.
3. Ensure the shelf clip is not loose or able to wiggle out of the shelf standard. See figs. 3 and 4.
4. Place the shelves on the shelf clips with the cross support bars facing down.

**NOTICE >** Be sure all shelf corners are properly seated.

#### Shelf Adjustment

Shelving is adjustable for customer application. This appliance meets the IEC Shelf Weight Capacity of 47lb/ft<sup>2</sup> (230kg/m<sup>2</sup>).

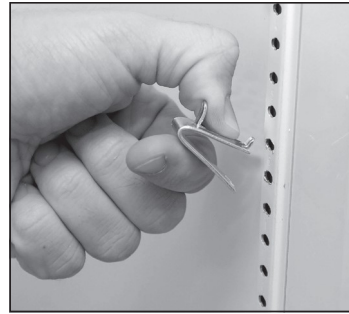

Fig. 1. Installing top tab of shelf clip.



Fig. 2. The bottom tab of the shelf clip will fit tightly.



Fig. 3. You may need to squeeze or twist the bottom of the shelf clip to install.



Fig. 4. Installed shelf clip.

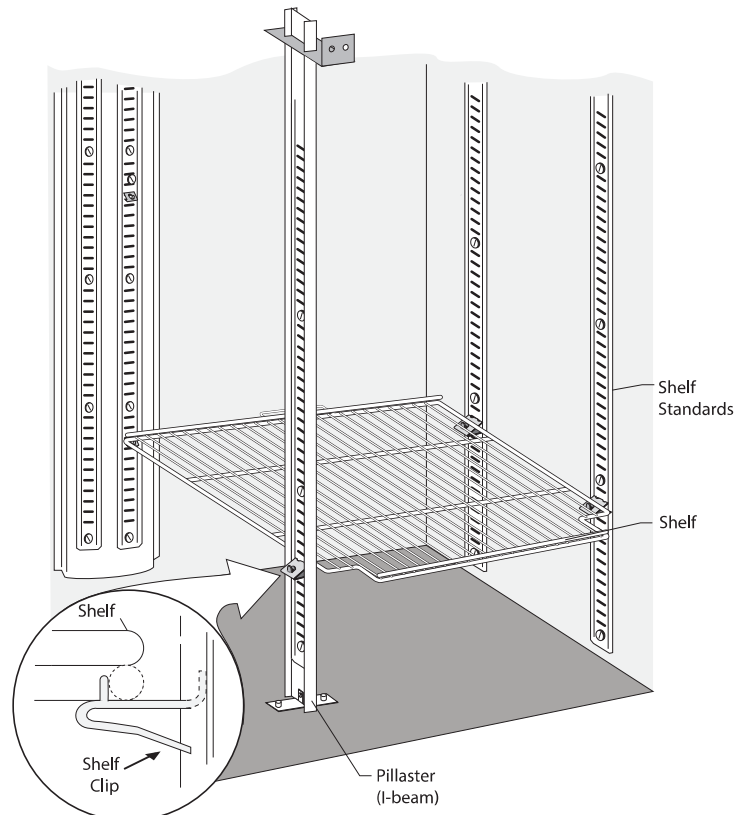



# Installation & Setup (cont.)

## Ensuring Correct Airflow (TPP Models Only)

### ⓘ USER ACTION!

**!** **DO NOT** remove the baffles from their original locations. Removing baffles from the condiment pan area will adversely affect refrigeration performance. See figs. 1 and 2.

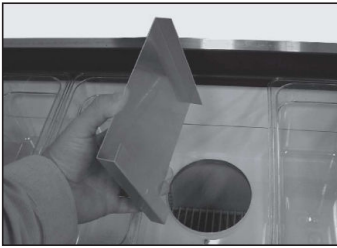

**Fig. 1.** Position baffle over the holes in the condiment pan area.

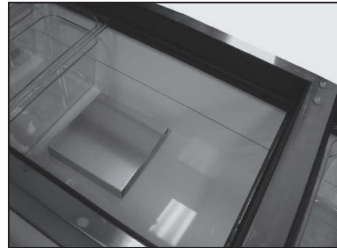

**Fig. 2.** Correctly positioned baffle..

## Drawer Removal and Installation

### Drawer Style #1

#### Removal

1. Completely open the drawer.
2. Locate the roller clips (in down position; see figs. 1 and 2).
3. While holding the sides of the drawer, rotate the roller clips upward. See fig. 3.
4. Lift the drawer from the channel slot. See fig. 4.

#### Installation

1. With the roller clips in the up position (see fig. 3), lower the drawer's rear rollers into the channel slots.
2. Push the drawer into position.
3. Rotate the roller clips to the down position. See figs. 1 and 2.

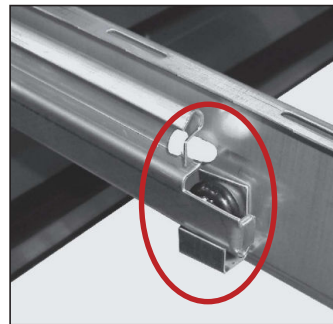

**Fig. 1.** Roller clip location.

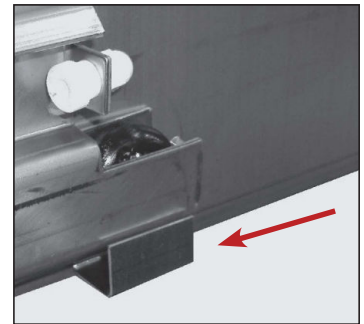

**Fig. 2.** Roller clip in down position.

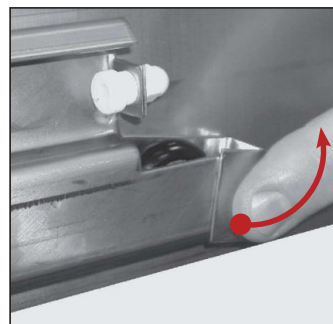

**Fig. 3.** Rotate the roller clip upward

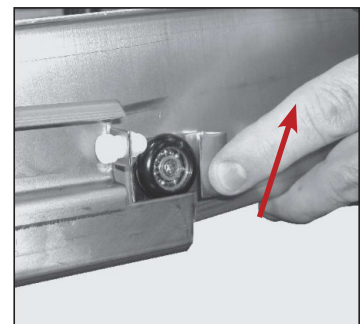

**Fig. 4.** Lift and remove drawer.

## Installation & Setup (cont.)

### Drawer Removal and Installation (cont.)

#### Drawer Style #2

##### Removal

1. Slide the drawer out and locate the plastic drawer retainer. See fig. 5
2. Push the plastic drawer retainer forward and raise the front end. See figs. 6a and 6b.
3. Remove the drawer.

##### Installation

1. With the plastic drawer retainer raised, align the drawer with the slide and push the drawer into position. See figs. 6b and 7.
2. Align the drawer with the drawer slide and push the drawer into position.
3. Press the plastic drawer retainer down and towards the back of the cabinet. See fig. 7.
4. Verify correct drawer operation.

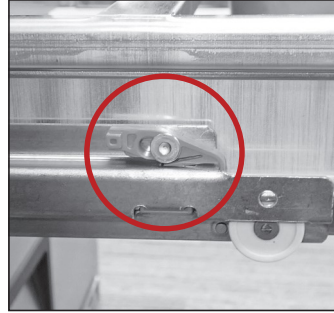

**Fig. 5.** Drawer retainer location. Retainer is engaged.

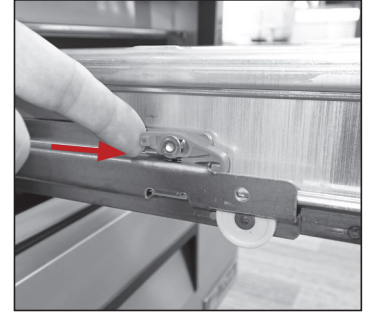

**Fig. 6a.** Push the retainer forward.

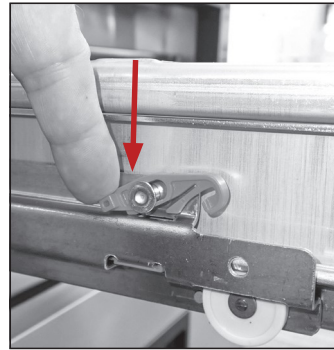

**Fig. 6b.** Push the back of the retainer down.



**Fig. 7.** Align the drawer with the drawer slide.